

IS: 2502 - 1963
(Reaffirmed 1990)

Indian Standard

**CODE OF PRACTICE FOR
BENDING AND FIXING OF BARS FOR
CONCRETE REINFORCEMENT**

Twelfth Reprint MARCH 1998

UDC 691.87-42:693.554

© *Copyright* 1964

BUREAU OF INDIAN STANDARDS
MANAK BHAVAN, 9 BAHADUR SHAH ZAFAR MARG
NEW DELHI 110002

Indian Standard

CODE OF PRACTICE FOR BENDING AND FIXING OF BARS FOR CONCRETE REINFORCEMENT

Joint Sectional Committee for Concrete Reinforcement, BSMDC 8

Chairman

SHRI C. P. MALIK

Representing

National Buildings Construction Corporation Ltd,
New Delhi

Members

SHRI K. F. ANTIA	M. N. Dastur & Co (Private) Ltd, Calcutta
SHRI B. B. BHATTACHARJEE	I.R.C. Weldmesh Ltd, Calcutta
SHRI N. G. DEWAN	Central Public Works Department
SHRI K. G. RAJAGOPALAN (<i>Alternate</i>)	
SHRI V. DORASWAMY	Iron & Steel Control, Calcutta
SHRI K. R. N. SWAMY (<i>Alternate</i>)	
SHRI B. N. GUPTA	The Steel Re-rolling Mills Association of India, Calcutta
SHRI P. K. GUPTA	National Metallurgical Laboratory (CSIR), Jamshedpur
SHRI M. A. HAFEEZ	National Buildings Organization (Ministry of Works, Housing & Rehabilitation)
ASSISTANT DIRECTOR (DESIGNS) (<i>Alternate</i>)	
SHRI HARCHAND SINGH	Indian Steel & Wire Products Ltd, Jamshedpur
SHRI R. R. KAPLISH (<i>Alternate</i>)	
JOINT DIRECTOR STANDARDS (B&S), RESEARCH, DESIGNS & STANDARDS ORGANIZATION	Railway Board (Ministry of Railways)
SHRI K. N. KUDALKAR	Gammon India Ltd, Bombay
DR A. K. MALLIK	Hindustan Steel Ltd, Rourkela
DR A. KHAN (<i>Alternate</i>)	

(Continued on page 2)

BUREAU OF INDIAN STANDARDS
MANAK BHAVAN, 9 BAHADUR SHAH ZAFAR MARG
NEW DELHI 110002

IS : 2502 - 1963

(Continued from page 1)

<i>Members</i>	<i>Representing</i>
SHRI S. C. MAZUMDAR	Gannon Dunkerley & Co Ltd, New Delhi
SHRI S. K. GUHA THAKURTA (<i>Alternate</i>)	
SHRI N. H. MOHILE	The Concrete Association of India, Bombay
SHRI C. L. N. JYENGAR (<i>Alternate</i>)	
SHRI M. P. NAGARSHETH	Roads Wing, Ministry of Transport & Communications
SHRI G. VENKATESULU (<i>Alternate</i>)	
SHRI E. K. N. NAMBIAR	Directorate General of Supplies & Disposals (Ministry of Economic & Defence Co-ordination)
DR I. C. DOS M. PAIS CUDDOU	Central Water & Power Commission (Ministry of Irrigation & Power)
SHRI Y. K. MURTHY (<i>Alternate</i>)	
SHRI B. K. PANTHAKY	Hindustan Construction Co Ltd, Bombay
SHRI RADHEY SHIAM	Engineer-in-Chief's Branch, Army Headquarters
PROF G. S. RAMASWAMY	Central Building Research Institute (CSIR), Roorkee
SHRI K. SIVA PRASAD (<i>Alternate</i>)	
SECRETARY	Central Board of Irrigation & Power, New Delhi
SHRI V. M. TALATI	Spunpipe & Construction Co (Baroda) Ltd, Baroda
SHRI Y. L. TANDON	Railway Testing & Research Centre (Railway Board), Lucknow
SHRI N. M. THADANI	Sahu Cement Service, New Delhi
DR H. C. VISVESVARAYA, Deputy Director (Bldg)	Director, ISI (<i>Ex-officio Member</i>)

Secretary

SHRI A. PRITHIVI RAJ
Extra Assistant Director (Bldg), ISI

Indian Standard

CODE OF PRACTICE FOR BENDING AND FIXING OF BARS FOR CONCRETE REINFORCEMENT

0. FOREWORD

0.1 This Indian Standard was adopted by the Indian Standards Institution on 21 September 1963, after the draft finalized by the Joint Sectional Committee for Concrete Reinforcement had been approved by the Building Division Council and the Structural and Metals Division Council.

0.2 This standard is prepared with a view to assisting designers, engineers and contractors in drawing up precise bending schedules for reinforcement used in reinforced concrete construction, and also in the fixing of reinforcement. Though, it is well appreciated that much of time and effort can be saved on the site if rational dimensions for shaping the bars are supplied to the bar benders; different practices have been followed hitherto in drawing up the bar bending schedule. It is attempted in this standard to unify the various practices followed and to rationalize the bending schedule to correspond with metric series of reinforcement.

0.3 Bar bending is an operation which requires adequate supervision, skilled workmanship and efficient equipment; and any attempt to carry out the work with unskilled labour and inefficient tools will undoubtedly result in unsatisfactory work. In view of this, certain recommended methods of bar bending are also included in this standard.

0.4 Though this standard is primarily intended for the preparation of bending schedule for reinforced concrete work, it may also be generally adopted for mild steel reinforcement used in prestressed concrete work.

0.5 The Sectional Committee responsible for the preparation of this standard has taken into consideration the views of producers, consumers and technologists and has related the standard to the manufacturing and trade practices followed in the country in this field. Due weightage has also been given to the need for international co-ordination among standards prevailing in different countries of the world. These considerations led the Committee to derive assistance from the following Publications:

DRAFT REVISION OF B.S. 1478:1948 BENDING DIMENSIONS AND SCHEDULING OF BARS FOR THE REINFORCEMENT OF CONCRETE. British Standards Institution.

IS : 2502 - 1963

ACI 315-1951 MANUAL OF STANDARD PRACTICE FOR DETAILING REINFORCED CONCRETE STRUCTURES. American Concrete Institute.

0.6 Wherever a reference to any Indian Standard appears in this code, it shall be taken as a reference to its latest version.

0.7 This standard is intended chiefly to cover the technical provisions relating to bending and fixing of bars for concrete reinforcement, and it does not include all the necessary provisions of a contract.

1. SCOPE

1.1 This standard covers symbols and approximate dimensions of bends, and bending and fixing procedures for reinforcement,

1.2 The dimensioning and bending of bars specified in this standard applies principally to reinforcement bars conforming to*IS: 432-1960 Specification for Mild Steel and Medium Tensile Steel Bars and Hard-Drawn Steel Wire for Concrete Reinforcement (*Revised*). They may also be used in the case of bars conforming to the following specifications with such modifications as may be found necessary:

†IS: 1139-1959 HOT ROLLED MILD STEEL AND MEDIUM TENSILE STEEL DEFORMED BARS FOR CONCRETE REINFORCEMENT

†IS: 1786-1961 COLD-TWISTED STEEL BARS FOR CONCRETE REINFORCEMENT

2. FORM OF SCHEDULE

2.1 In conjunction with the requirements of this code, standard form of reinforcement schedule as shown in Table I shall be used for purposes of detailing reinforcement in concrete work.

3. BEND DIMENSIONS AND SYMBOLS

3.1 General — The dimensions of bends should be so given that a minimum amount of calculation is necessary for marking off bars and setting the machine and stops. The dimensioning procedure shown in Fig. 1 and Tables II to IX (*see p. 7 to 14*) should be adopted as far as possible.

3.1.1 Where no indication is given to the contrary, the angle between the portions of a bar at a bend shall be assumed to be a right angle. Bending dimensions in which angles are expressed in degrees should be avoided as far as possible. When bending bars of large diameter, care should be taken to ensure that the overall length of the bent bar does not exceed the theoretical or calculated length.

3.1.2 When the shape of any bent bar is other than those covered by Tables III to IX but is made up by combining two or more shapes, the

*Since second revision issued as IS : 432 (Part I)-1966 and IS : 432 (Part II)-1966.

†Since revised.

TABLE I STANDARD FORM OF REINFORCEMENT SCHEDULE

(Clause 2.1)

Schedule Number

LOCATION	MARK DESIGNATION	SIZE AND TYPE	NUMBER OF SETS	NUMBER PER SET	TOTAL NUMBER	LENGTH	SHAPE (ALL DIMENSIONS ARE IN ACCORDANCE WITH THIS STANDARD UNLESS OTHERWISE STATED)
(1)	(2)	(3)	(4)	(5)	(6)	(7)	(8)
Column	C4 4R 25N	MS round 25 mm	5	4	20	3 000 mm	Straight

NOTE 1 — The recommended widths of the above columns are reading from left to right 25, 20, 15, 15, 15, 15 and 75 mm. The 75 mm dimension may be reduced to 70 mm for paper sizes other than *A4. Adequate margin should be provided on either side, the left-hand margin being not less than 15 mm. The length of the form should not generally exceed that of *A4 size.

NOTE 2 — In col 2, the bar identification that will be put on the labels attached to the bars shall appear. It should be simple. The first number in the mark designation refers to the number of identical bars in similar locations in the same section of a given member, and the letter *R* refers to round bars, the figure that follows the letter *R* represents the diameter or the nominal size of the bar in millimetres and *N* represents the identification number of the bar/bars given consecutively.

NOTE 3 — In col 3, the quality and basic shape of the reinforcement bar shall be specified.

*A4 size is 210 × 297 mm.

bending dimensions shall be measured as shown for appropriate standard shapes. Where the shape of a bent bar is such that it cannot be obtained even by combining two or more standard shapes, the bars shall be fully dimensioned in the schedule and also the method of measuring the bending dimensions shall be indicated in the schedule; but such special shapes should be avoided as far as possible.

3.2 Bends and Hooks Forming End Anchorages

3.2.1 *Dimensions of Bends and Hooks* — Unless otherwise indicated in the schedule, a semicircular hook or a bend forming an anchorage to a bar shall be bent with an internal radius in accordance with Fig. 1A and Fig. 1B, respectively. The hook and bend allowances shall be in accordance with Table II.

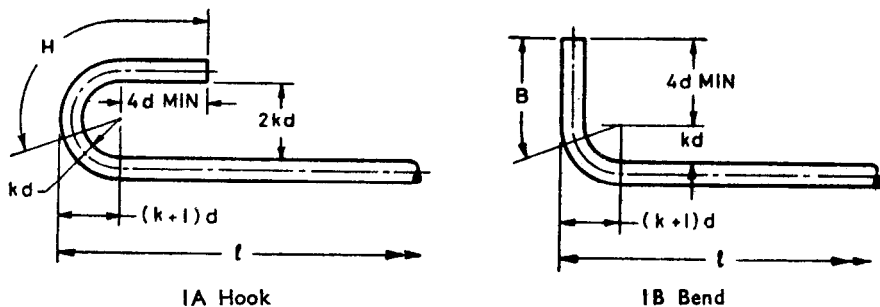

NOTE 1 — k has a value of 2, in the case of mild steel conforming to ^{*}IS: 432-1960 Specification for Mild Steel and Medium Tensile Steel Bars and Hard-Drawn Steel Wire for Concrete Reinforcement (*Revised*) or [†]IS: 1139-1959 Specification for Hot Rolled Mild Steel and Medium Tensile Steel Deformed Bars for Concrete Reinforcement; 3, in the case of medium tensile steel conforming to ^{*}IS: 432-1960 or [†]IS: 1139-1959; and 4, in the case of cold worked steel conforming to [†]IS: 1786-1961 Specification for Cold Twisted Steel Bars for Concrete Reinforcement. In the case of bars above 25 mm, however, it is desirable to increase the k value to 3, 4 and 6 respectively.

NOTE 2 — H and B refer to hook allowance and bend allowance respectively (see Table II).

FIG. 1 STANDARD HOOK AND BEND

3.3 Binders, Stirrups, Links and the Like — In the case of binders, stirrups, links, etc, the straight portion beyond end of the curve at the end shall be not less than eight times the nominal size of the bar.

4. CURVED BARS

4.1 Bars specified to be formed to radii exceeding those given in Table X (see p. 15) need not be bent, but the required curvature may be obtained during placing.

5. BENDING AND CUTTING TOLERANCES

5.1 Bars shall be bent in accordance with the appropriate dimensions shown in the schedule. Where an overall or an internal dimension of the bent bar is specified, the tolerance, unless otherwise stated, shall be as in Table XI (see p. 15).

5.1.1 Any excess in length of bar supplied over the total of the lengths of the various portions of the bar between bends, including the specified tolerances or not, shall be taken up in the end anchorages, or in that portion of the bar which shall be indicated on the schedule. The cutting lengths shall be specified to the next greater whole 25 mm of the sum of the bending dimensions and allowance.

^{*}Since second revision issued as IS : 432 (Part I)-1966 and IS : 432 (Part II)-1966.

[†]Since revised.

TABLE II HOOK AND BEND ALLOWANCES

(Clauses 3.1 and 3.2.1)

NOMINAL SIZE OF BAR	HOOK ALLOWANCE (H)						BEND ALLOWANCE (B)					
	Mild Steel Conforming to *IS: 432-1960 or to †IS: 1139- 1959		Medium Tensile Steel Conforming to *IS: 432-1960 or to †IS: 1139- 1959		Cold Worked Steel Bars Conforming to ‡IS: 1786-1961		Mild Steel Conforming to *IS: 432-1960 or to †IS: 1139- 1959		Medium Tensile Steel Conforming to *IS: 432-1960 or to †IS: 1139- 1959		Cold Worked Steel Bars Conforming to ‡IS: 1786-1961	
	Min	Re- commd	Min	Re- commd	Min	Re- commd	Min	Re- commd	Min	Re- commd	Min	Re- commd
	mm	mm	mm	mm	mm	mm	mm	mm	mm	mm	mm	mm
5	75	—	75	—	75	—	75	—	75	—	75	—
6	75	—	75	—	75	—	75	—	75	—	75	—
8	75	—	90	—	105	—	75	—	75	—	75	—
10	90	—	110	—	130	—	75	—	75	—	75	—
12	110	—	130	—	155	—	75	—	75	—	75	—
16	145	—	175	—	210	—	80	—	90	—	95	—
20	180	—	220	—	260	—	100	—	110	—	120	—
22	200	—	240	—	285	—	110	—	120	—	130	—
25	225	—	275	—	325	—	125	—	140	—	150	—
28	250	310	310	365	365	475	146	155	155	170	170	195
32	290	350	350	415	415	545	160	175	175	190	190	225
36	325	395	395	470	470	610	180	200	200	215	215	250
40	360	440	440	520	520	680	200	220	220	240	240	280
45	405	495	495	585	585	765	225	250	250	270	270	315
50	450	550	550	650	650	850	250	275	275	300	300	350

H = Hook allowance taken as 9d, 11d, 13d and 17d for k values 2, 3, 4 and 6 respectively and rounded off to the nearest 5 mm, but not less than 75 mm.

B = Bend allowance taken as 5d, 5.5d, 6d and 7d for k values 2, 3, 4 and 6 respectively and rounded off to the nearest 5 mm, but not less than 75 mm.



*IS: 432-1960 Specification for Mild Steel and Medium Tensile Steel Bars and Hard-Drawn Steel Wire for Concrete Reinforcement (Revised). (Since revised).

†IS: 1139-1959 Specification for Hot Rolled Mild Steel and Medium Tensile Steel Deformed Bars for Concrete Reinforcement. (Since revised).

‡IS: 1786-1961 Specification for Cold Twisted Steel Bars for Concrete Reinforcement. (Since revised).

TABLE III MEASUREMENT OF BENDING DIMENSIONS OF BARS FOR REINFORCED CONCRETE

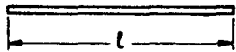
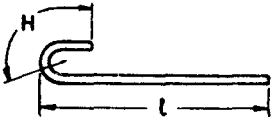
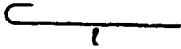
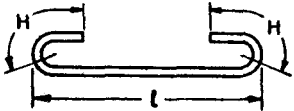
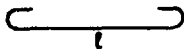
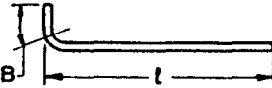
(Clauses 3.1 and 3.1.2)

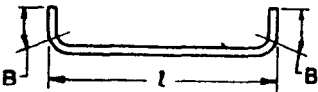
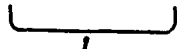
REF No.	METHOD OF MEASUREMENT OF BENDING DIMENSIONS	APPROX TOTAL LENGTH OF BAR (L) MEASURED ALONG CENTRE LINE	SKETCH AND DIMENSIONS TO BE GIVEN IN SCHEDULE
A		l	STRAIGHT
B		$l+H$	
C		$l+2H$	
D		$l+B$	
E		$l+2B$	

NOTE 1 — Where a hook is to be formed at right angles to the plane in which the bending sketch of the bar is drawn in the schedule, the hook shall be indicated as below and marked either 'hook up' or 'hook down':

Hook up ←

Hook down ←

NOTE 2 — H and B refer to hook allowance and bend allowance respectively.

TABLE IV MEASUREMENT OF BENDING DIMENSIONS OF BARS FOR REINFORCED CONCRETE

(Clauses 3.1 and 3.1.2)

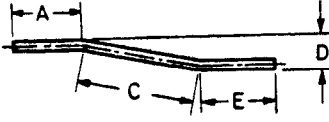
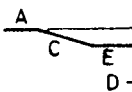
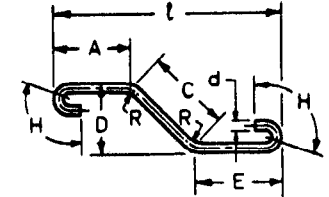
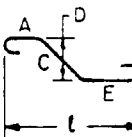
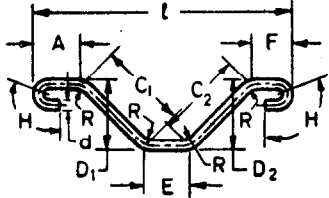
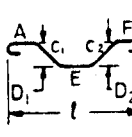
REF No.	METHOD OF MEASUREMENTS OF BENDING DIMENSIONS	APPROX TOTAL LENGTH OF BAR (L) MEASURED ALONG CENTRE LINE	SKETCH AND DIMENSIONS TO BE GIVEN IN SCHEDULE
A		<p>Where C is more than 3D</p> $A + C + E$	
B		<p>If angle with horizontal is 45° or less, and R is 12d or less</p> $A + C + E + 2H \text{ or } l + 2H + C - \sqrt{C^2 - D^2}$ <p>(If l is specified, A or E is omitted)</p>	 <p>(See Note 2)</p>
C		<p>If angle with horizontal is 45° or less, and R is 12d or less</p> $A + C_1 + C_2 + E + F + 2H \text{ or } l + C_1 + C_2 + 2H - \sqrt{C_1^2 - D_1^2} - \sqrt{C_2^2 - D_2^2}$ <p>(If l is specified, A, E or F is omitted)</p>	 <p>(See Note 2)</p>

NOTE 1 — Where a hook is to be formed at right angles to the plane in which the bending sketch of the bar is drawn in the schedule, the hook shall be indicated as below and marked either 'hook up' or 'hook down':

Hook up ←——



Hook down ←——

NOTE 2 — The internal radius R shall be specified if it is other than that given in 3.2.1.

NOTE 3 — H and B refer to hook allowance and bend allowance respectively.

TABLE V MEASUREMENT OF BENDING DIMENSIONS OF BARS FOR REINFORCED CONCRETE

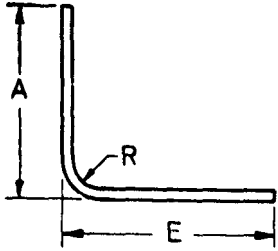
(Clauses 3.1 and 3.1.2)

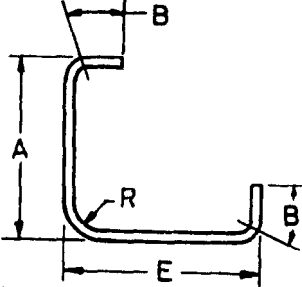
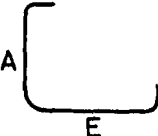
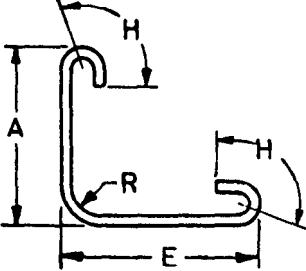
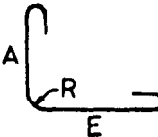
REF. No.	METHOD OF MEASUREMENT OF BENDING DIMENSIONS	APPROX TOTAL LENGTH OF BAR (L) MEASURED ALONG CENTRE LINE	SKETCH AND DIMENSIONS TO BE GIVEN IN SCHEDULE
A		$A + E - \frac{1}{2}R - d$	 <p>(See Notes 2 and 3)</p>
B		$A + E - \frac{1}{2}R - d + 2B$	 <p>(See Notes 2 and 3)</p>
C		$A + E - \frac{1}{2}R - d + 2H$	 <p>(See Notes 2 and 3)</p>

NOTE 1 — Where a hook is to be formed at right angles to the plane in which the bending sketch of the bar is drawn in the schedule, the hook shall be indicated as below and marked either 'hook up' or 'hook down':

Hook up ←

Hook down ←

NOTE 2 — The internal radius R shall be specified if it is other than that given in 3.2.1.

NOTE 3 — H , B and d refer to hook allowance, bend allowance and nominal size of bar respectively.

TABLE VI MEASUREMENT OF BENDING DIMENSIONS OF BARS FOR REINFORCED CONCRETE

(Clauses 3.1 and 3.1.2)

REF NO.	METHOD OF MEASUREMENT OF BENDING DIMENSIONS	APPROX TOTAL LENGTH OF BAR (<i>L</i>) MEASURED ALONG CENTRE LINE	SKETCH AND DIMENSIONS TO BE GIVEN IN SCHEDULE
A		$A + E + 1\frac{1}{2}D + 2H$	
B		<p>If angle with horizontal is 45° or less</p> $A + E$	<p>(See Note 2)</p>
C		<p>If angle with horizontal is 45° or less and <i>R</i> is 12<i>d</i> or less</p> $A + E + 2H$ <p>If angle is greater than 45° and <i>R</i> exceeds 12<i>d</i>, <i>L</i> to be calculated</p>	<p>(See Note 2)</p>
D		<p>If angle with horizontal is 45° or less</p> $A + B + C + H - 2(R + d)$ <p>If angle is greater than 45° and <i>R</i> exceeds 12<i>d</i>, <i>L</i> to be calculated</p>	<p>(See Note 2)</p>
E		$l + 2H$	<p>(See Note 2)</p>

NOTE 1 — Where a hook is to be formed at right angles to the plane in which the bending sketch of bar is drawn in the schedule, the hook shall be indicated as below and marked either 'hook up' or 'hook down':

Hook up ———

Hook down ———



NOTE 2 — The internal radius *R* shall be specified if it is other than that given in 3.2.1.

NOTE 3 — *H* and *B* refer to hook allowance and bend allowance respectively.

NOTE 4 — Dimensions *X* and *Y* should be practical dimensions to enable the angle of the bend to be determined.

TABLE VII MEASUREMENT OF BENDING DIMENSIONS OF BARS FOR REINFORCED CONCRETE

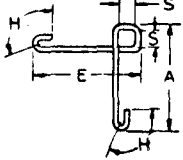
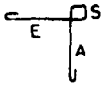
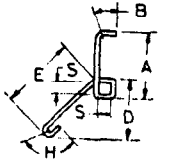
(Clauses 3.1 and 3.1.2)

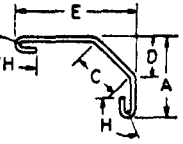
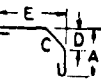
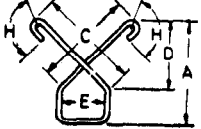
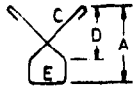
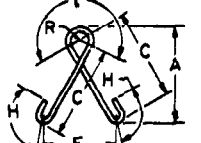
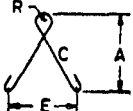
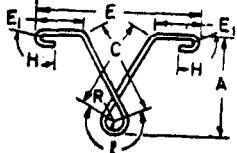
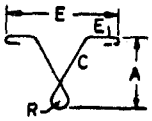





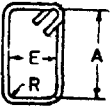

REF NO.	METHOD OF MEASUREMENT OF BENDING DIMENSIONS	APPROX TOTAL LENGTH OF BAR (L) MEASURED ALONG CENTRE LINE	SKETCH AND DIMENSIONS TO BE GIVEN IN SCHEDULE
A		$A + E + 2S + 2H + d$	 <p>(See Notes 1 and 2)</p>
B		$A + E + 8S + 2d + B + H$	 <p>(See Notes 1 and 2)</p>
C		$A + E + C + 2H - \sqrt{C^2 - D^2} - D$	 <p>(See Note 1)</p>
D		$E + 2(A - D + C + H)$	 <p>(See Note 1)</p>
E		$l + 2C + 2H$	
F		$2C + 2E_1 + l + 2H$	 <p>(See Note 1)</p>

NOTE 1 — The internal radius *R* shall be specified if it is other than that given in 3.2.1.

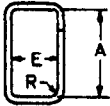
NOTE 2 — *H*, *B* and *d* refer to hook allowance, bend allowance and a nominal size of bar respectively.

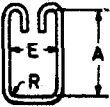
TABLE VIII MEASUREMENT OF BENDING DIMENSIONS FOR BINDERS, STIRRUPS, LINKS AND THE LIKE FOR REINFORCED CONCRETE

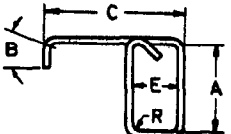
(Clauses 3.1 and 3.1.2)

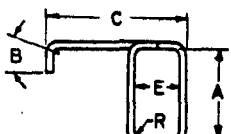
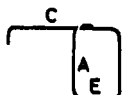
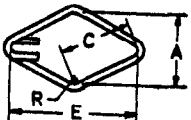
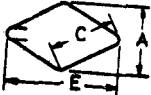
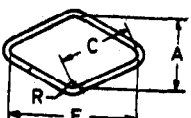
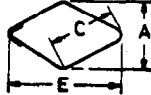
REF No.	METHOD OF MEASUREMENT OF BENDING DIMENSION	APPROX TOTAL LENGTH OF BAR (L) MEASURED ALONG CENTRE LINE	SKETCH AND DIMENSIONS TO BE GIVEN IN SCHEDULE
A		$2(A + E) + 24d$	 (See Notes 1 and 3)
B		$2(A + E) + 20d$	 (See Notes 1 and 3)
C		$2A + E + 28d$	 (See Notes 1 and 3)
D		$2A + E + C + 12d + B$	 (See Notes 1 and 3)
E		$2A + E + C + 9d + B$	 (See Notes 1 and 3)
F		$4C + 24d$	 (See Notes 1 and 3)
G		$4C + 20d$	 (See Notes 1 and 3)

Note 1 — The internal radius R of the corners of binders, stirrups, etc, shall be specified if it is other than that given in 3.2.1.

Note 2 — If the form of the bar is such that there may be doubt as to which is the inside of the bar, arrows should be shown on the bending schedule and the dimension stated with the suffix OD or ID (outside or inside dimension).

Note 3 — B and d refer to bend allowance and nominal size of bar respectively.

TABLE IX MEASUREMENT OF BENDING DIMENSIONS FOR BINDERS, STIRRUPS, LINKS AND THE LIKE FOR REINFORCED CONCRETE

(Clauses 3.1 and 3.1.2)

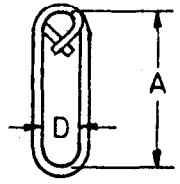
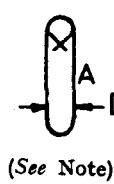
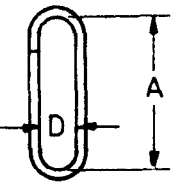
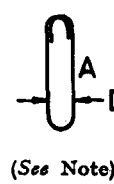
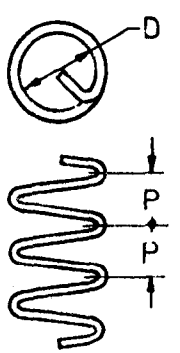
REF No.	METHOD OF MEASUREMENT OF BENDING DIMENSIONS	APPROX TOTAL LENGTH OF BAR (L) MEASURED ALONG CENTRE LINE	SKETCH AND DIMENSIONS TO BE GIVEN IN SCHEDULE
A		$2A + 3D + 22d$	 (See Note)
B		$2A + 3D + 22d$	 (See Note)
C		<p>Where P is not greater than $D/5$</p> $N \pi (D+d) + 8d$ <p> N = number of complete and fractional turns D = internal dia P = pitch of helix d = size of bar </p>	<p style="text-align: center;">—</p>

NOTE — d refers to nominal size of bar.

TABLE X BARS BENT TO A RADIUS

(Clause 4.1)

NOMINAL SIZE	CRITICAL RADIUS
mm	m
5	2.0
6	2.5
10	3.5
12	5.0
16	8.0
20	12.0
22	18.0
25	24.0
28	34.0
32	40.0

TABLE XI PERMISSIBLE BENDING AND CUTTING TOLERANCES

(Clause 5.1)

	DIMENSION		TOLERANCE	
	Over	Up to and Including	Plus	Minus
	cm	cm	mm	mm
For Bend Bars	—	75	3	5
	75	150	5	10
	150	250	6	15
	250	—	7	25
For Straight Bars	All lengths		25	25

5.1.2 The cutting tolerance for bars to be bent shall be the tolerance given for straight bars. To allow for this cutting tolerance when dimensioning bent bars, at least one dimension shall not be specified.

6. BENDING

6.1 General — Bars shall be bent cold except as provided in 6.1.1. Any type of equipment may be used for bending of bars with the prior approval of the engineer in-charge.

6.1.1 Bars larger than 25 mm in size may be bent hot at cherry-red heat (not exceeding 850°C) except those bars which depend for their strength on cold working. Hot bars shall not be cooled by quenching.

6.2 Equipment --- Bending of bars may be done either by improvised means or by hand-operated machines (see Fig. 2, 3 and 4), and by power-operated bender. For bars of 12 mm diameter and under, mechanical contrivances of the type illustrated in Fig. 2 may be advantageously employed.

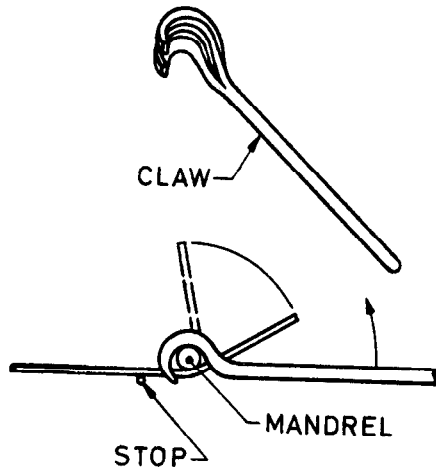

FIG. 2 BENDING OF BAR BY MEANS OF CLAW

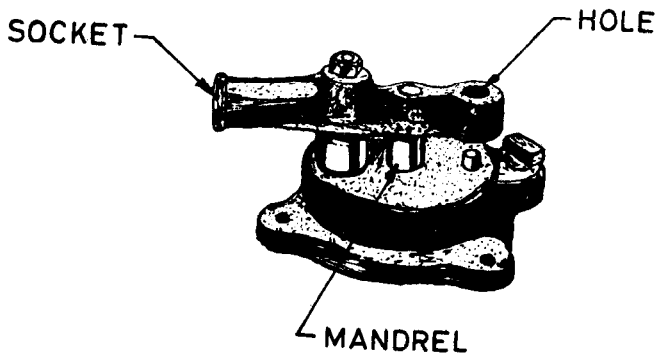

FIG. 3 SIMPLE BAR-BENDING MACHINE

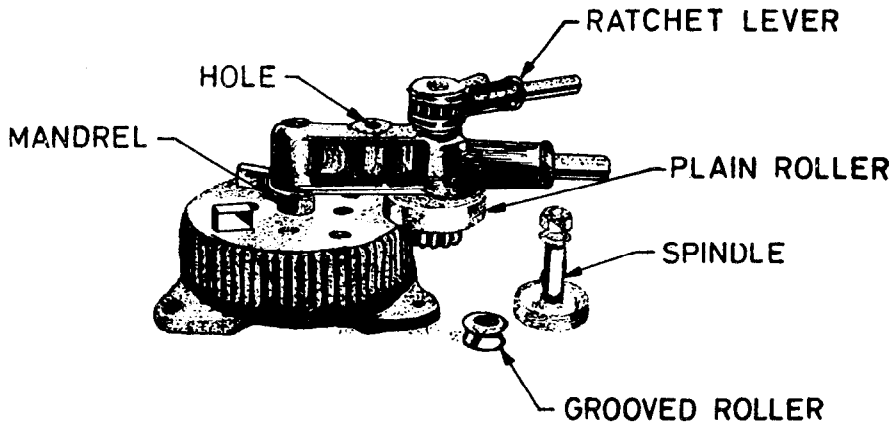

FIG. 4 GEARED BAR-BENDING MACHINE

6.2.1 Two of the most common types of bar-bending machines suitable for bending bars cold are shown in Fig. 3 and Fig. 4. The essential components of the machines are also illustrated in the figures. The hand machine shown in Fig. 3 could be employed for bending bars up to 16 mm diameter and for larger diameters geared bar bender shown in Fig. 4 is required. Special roller spindles may be necessary for bending deformed and twisted bars.

6.2.2 Bending of bars 36 mm and above require special equipment, such as power-operated benders. However, where only a few bars are to be bent, easy bends may be formed by jim-crow or rail bender, an appliance comprising of forged bow with a steel square threaded screw.

6.2.3 Where large quantities of bars are to be bent, power-operated benders may be advantageously used.

6.3 Operation — The hand-operated benders are generally mounted on tables. The various operations involved and the schematic way of bending are illustrated in Fig. 5. The bar to be bent should be placed between two stops driven into a steel or wooden table. The bar should be held rigid at one of the stops by a roller sitting over the mandrel. By using a tommy bar and levering, the bar may be bent to the desired angle.

6.4 Special patented appliances for bending bars into helical, rectangular and other shapes are available and they may also be used.

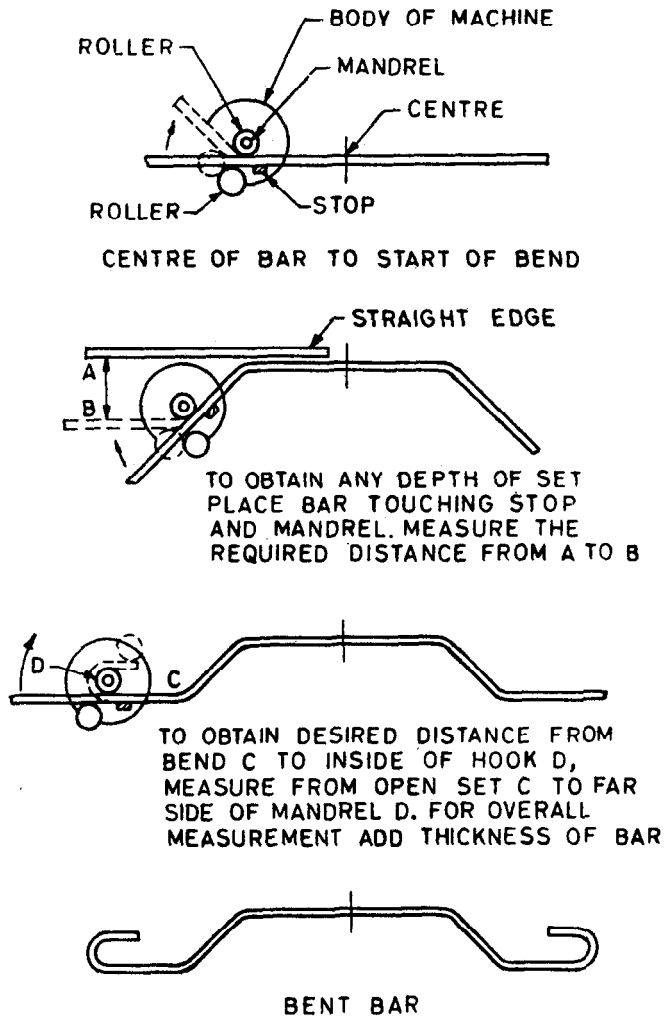

FIG. 5 BENDING OF BAR

7. FIXING REINFORCEMENT

7.1 General — The economy of reinforced concrete design will be fully realized only when the reinforcements are maintained at their designed

positions at all times. The important factors in fixing the reinforcement are precision and convenience.

7.1.1 Reinforcement shall be placed in position as given on the detailed design drawing and shall be secured at that position. In case of delay occurring between fixing of reinforcement and concreting, the position of the reinforcement shall be checked prior to concreting.

7.1.2 Lapping of bars shall be done in accordance with the relevant requirements specified in IS: 456-1964 Code of Practice for Plain and Reinforced Concrete (*Second Revision*). Laps shall be staggered.

7.1.3 The precautions described in 7.2 to 7.5 shall be taken to prevent displacement of reinforcement during shuttering and concreting.

7.2 Tying of Reinforcement Bars — Bars crossing each other, where required, shall be secured by binding wire (annealed) of size not less than 0.90 mm and conforming to IS: 280-1962 Specification for Mild Steel Wire (*Revised*), in such a manner that they will not slip over each other at the time of fixing and concreting.

7.2.1 Every compression bar shall be tied at least in two perpendicular directions.

7.2.2 Stirrups may be staggered, provided it is ensured that the corresponding stirrups form a uniform pattern in elevation.

7.2.3 Three methods of tying reinforcement bars are illustrated in Fig. 6; of the three methods, the method illustrated in Fig. 6A should be preferred to method given in Fig. 6B, and that given in Fig. 6B to the one given in Fig. 6C.

7.3 Cover Blocks

7.3.1 Cover blocks, which are generally of cement mortar, shall be used to ensure the required cover for reinforcement. Cover blocks are generally

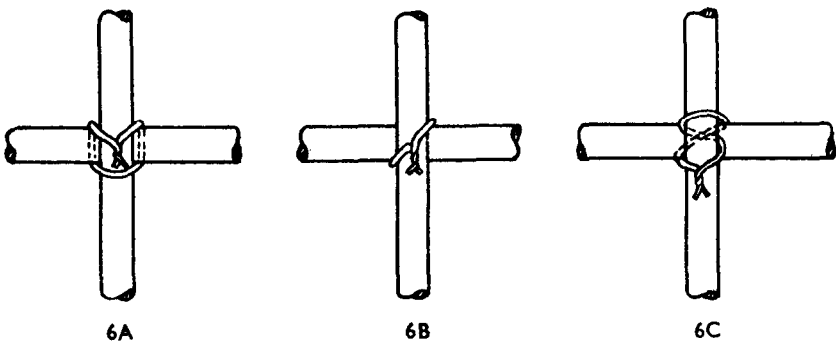

FIG. 6 THREE METHODS OF TYING REINFORCEMENT BARS

square or rectangular in plan with or without binding wire embedded in them which will be tied to the reinforcement at the time of placing (see Fig. 7). Rings with suitable hole at the centre may also be used.

7.3.2 The mortar or concrete used for the cover blocks or rings shall not be leaner than the mortar or concrete in which they will be embedded.

7.3.3 To provide necessary cover for reinforcement at any section, only single cover blocks shall be used.

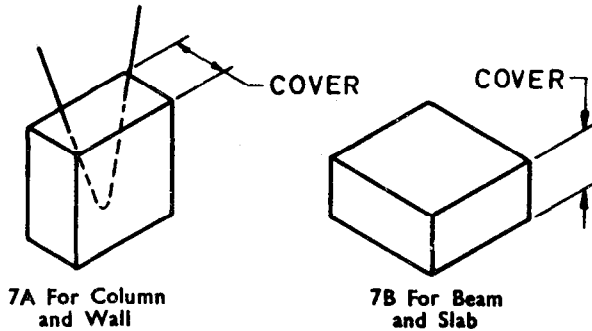

FIG. 7 COVER BLOCKS

7.4 Spacers

7.4.1 *Walls* — In walls where multiple rows of reinforcement are provided, it is very important that the distances between successive rows are properly maintained while concreting; and this may be achieved by following one of the methods illustrated in Fig. 8.

7.4.1.1 In the method illustrated in Fig. 8A, two rows of reinforcement are separated and kept in their correct relative position by being attached to an accurate bent bar that acts as distance piece while in the method illustrated in Fig. 8B the same effect is achieved by placing the vertical bars in slots accurately cut in a board with additional advantage of maintaining the correct cover. The slots may be placed by pairs of projecting nails and scribe marks on the board will indicate the correct alignment on the inside face of the shutters.

7.4.1.2 In the first method, the bar remains permanently in position but in the second method the spacer board has to be removed before the shutters.

7.4.2 *Slabs* — In slabs, whether double or multiple, layers of reinforcement are provided, the distances between the layers may be maintained by the method illustrated in Fig. 9.

7.4.2.1 In the figure, additional support bars are shown inserted; but in a good design, the provision of these extra bars would not be necessary as the designer would so arrange the reinforcement that the supporting bars would be a part of the principal reinforcement.

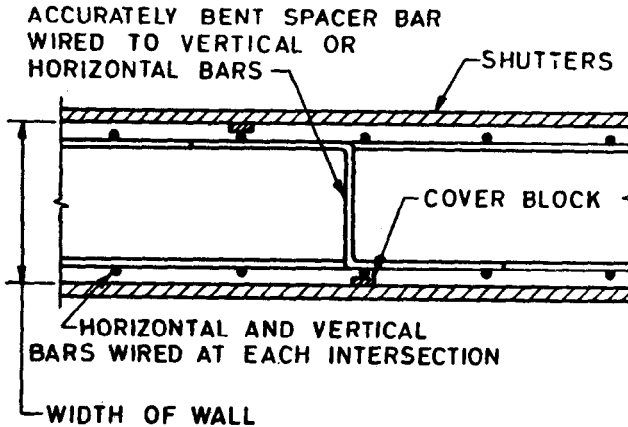

8A USE OF WALL SPACER BAR

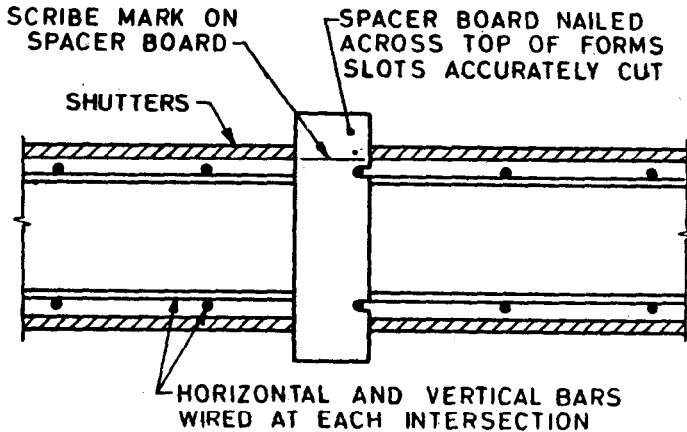

8B USE OF SPACER BOARD

FIG. 8 MAINTAINING WALL BARS IN POSITION

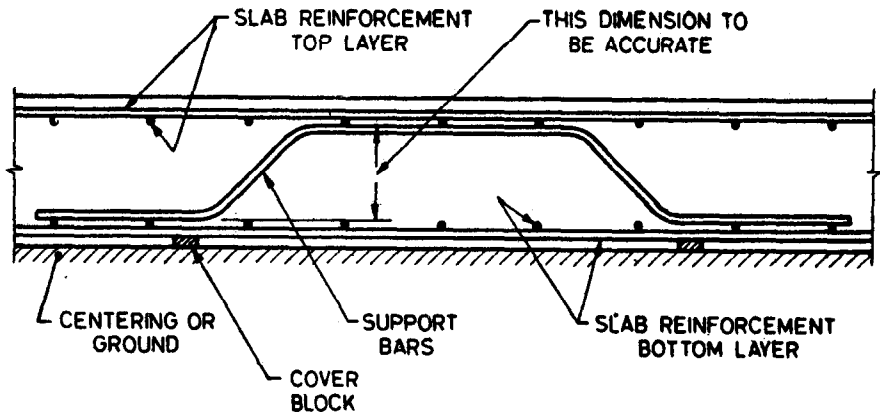

FIG. 9 DOUBLY REINFORCED SLAB

7.4.3 Beams — In beams with top reinforcement, it is desirable to suspend the top reinforcement from the formwork by suitable arrangements which may be removed on completion of concreting up to the appropriate level, unless such reinforcement is otherwise rigidly held in position by stirrups or other members.

7.5 Column Reinforcement — The column reinforcement, especially in heavily reinforced columns and in columns subjected to a combination of direct load and bending, should be properly tied, otherwise the strength of the column will be considerably affected. Some of the typical methods of tying the reinforcement are shown in Fig. 10. The ties may be staggered provided it is ensured that the corresponding ties form a uniform pattern in elevation and they shall be in closed loops.

7.6 Distortion of projecting vertical bars in double rows in walls may be prevented prior to completed assembly of horizontal reinforcement and erection of shutters by the arrangements illustrated in Fig. 11. This arrangement consists of a longitudinal timber or large bar placed along each row of vertical bar and tied to each bar. Between every sixth bar of opposite rows a cross piece of wood or steel should be tied.

7.6.1 For single vertical row of large bars in walls, a timber frame as illustrated in Fig. 12 may be employed to prevent the distortion of bar. The dimensions, details and spacing of the frame shall be determined by the nature of the work.

NOTE — The frame could often be part of the shuttering.

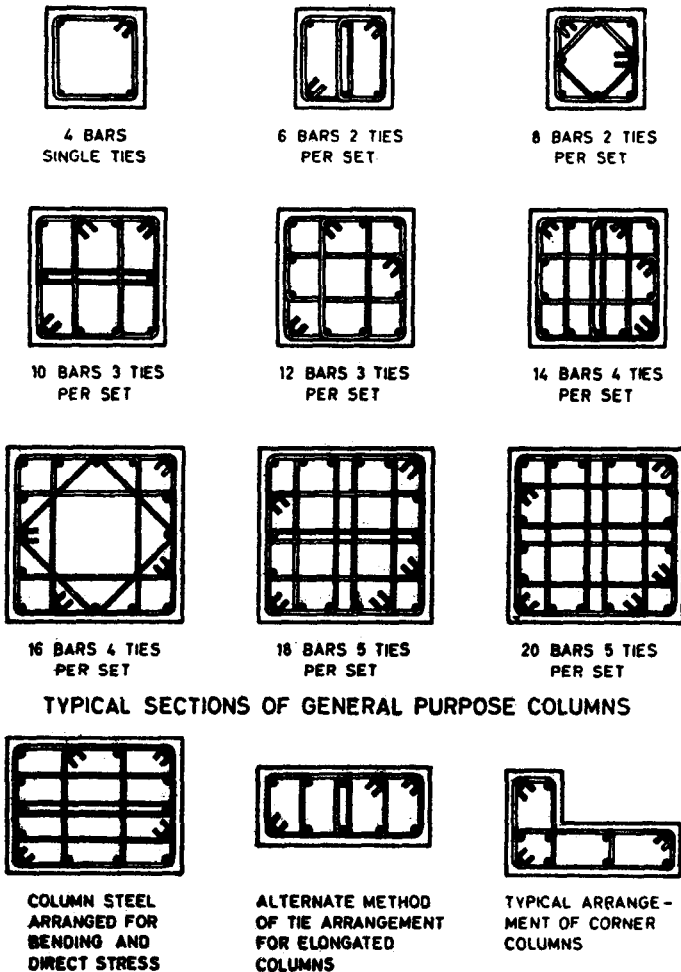

TYPICAL SECTIONS OF SPECIAL PURPOSE COLUMNS

NOTE 1 — If access to the interior of a column is necessary, a different pattern of ties may be substituted provided ties are so designed that each vertical bar is securely braced against movement.

NOTE 2 — The ties may be staggered provided it is ensured that the corresponding ties form a uniform pattern in the elevation.

FIG. 10 COLUMN TIES

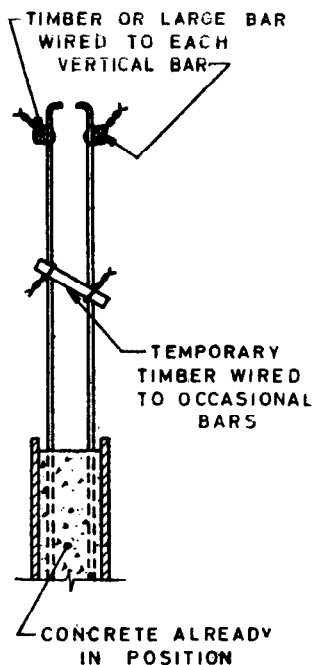

FIG. 11 STIFFENING OF PROJECTING VERTICAL WALL REINFORCEMENT

8. TRANSPORTING REINFORCEMENT

8.1 Reinforcement shall be transported to the site of work or to the place of storage by such means and in such a manner that the reinforcement is neither damaged nor deformed. The unloading of the reinforcement shall be done at the nearest convenient place where it is to be processed further. Particularly in cases where unloading is required to be done by hand, it is important that the vehicle should be brought as close as possible to the stacking or bending place in order to avoid carrying over long distances. As far as possible, at the time of unloading the bars should be separated by sizes and lengths.

9. STORAGE OF REINFORCEMENT

9.1 The actual location of the stacking place of reinforcement depends upon the site conditions, but it should be such that the reinforcement could be conveniently received and supplied to the operational centres in the site. On works covering large areas, it might be an advantage to stack the

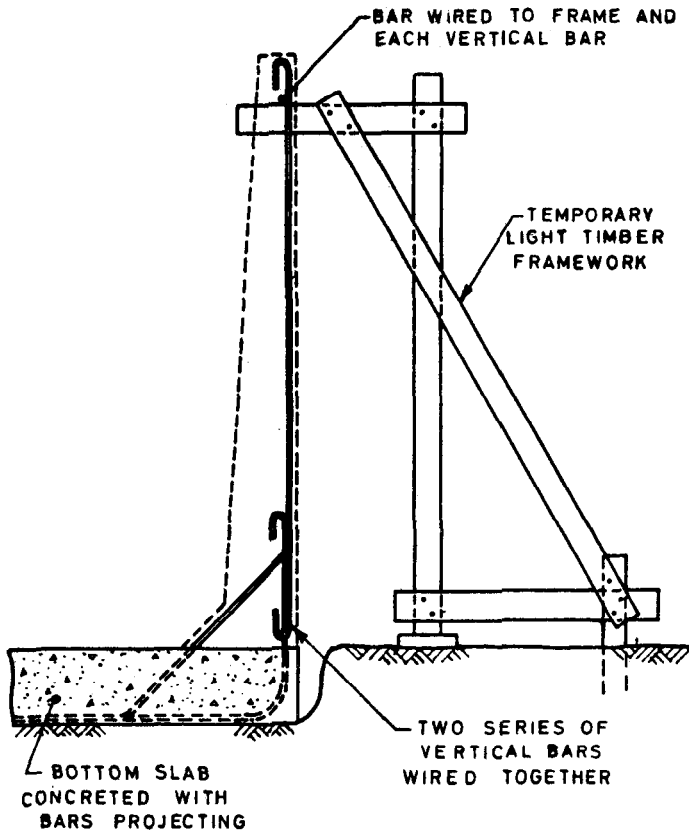

FIG. 12 SUPPORTING VERTICAL WALL REINFORCEMENT

reinforcement at different places close to the areas where they are likely to be used most.

9.1.1 In order to ensure that the reinforcement bars are kept in good condition, they should not be left in direct contact with the ground but they should be stacked on top of an arrangement of timber sleepers or the like. Suitable racks may also be used for stacking reinforcement in tiers. Where space is extremely limited, bars may also be stacked vertically but the vertical stacking has the disadvantage that it is more difficult to get the bars in and out and in identifying bars of different sizes and lengths. Whatever method of stacking is adopted, the bars should be stacked in

IS : 2502 - 1963

such a way that the various sizes and lengths can be quickly and easily identified.

9.1.2 After the reinforcement bars have been bent, they should be placed in the most convenient locations for transport to working points. Flexible bends like stirrups and bends of small diameter bars should be grouped together and bundled for ease of handling. Each bundle of bars or group of bars should have labels affixed to it indicating the bar mark, bending schedule reference number and its position in laying.

9.1.3 In storing bars, attention shall be paid to avoiding distortion and to preventing deterioration and corrosion.

9.1.4 Whilst a certain amount of hard rust on the reinforcement is considered desirable in reinforced concrete work, care should be taken to ensure that undue rusting or loose scaling do not take place in storage and in such conditions of weather where the reinforcement is likely to get corroded, the stack of reinforcement shall be suitably sheltered.

BUREAU OF INDIAN STANDARDS

Headquarters:

Manak Bhavan, 9 Bahadur Shah Zafar Marg, NEW DELHI 110002

Telephones: 323 0131, 323 3375, 323 9402

Fax : 91 11 3234062, 91 11 3239399, 91 11 3239382

Telegrams : Manaksanstha

(Common to all Offices)

Telephone

Central Laboratory :

Plot No. 20/9, Site IV, Sahibabad Industrial Area, Sahibabad 201010

8-77 00 32

Regional Offices:

Central : Manak Bhavan, 9 Bahadur Shah Zafar Marg, NEW DELHI 110002 323 76 17

*Eastern : 1/14 CIT Scheme VII M, V.I.P. Road, Maniktola, CALCUTTA 700054 337 86 62

Northern : SCO 335-336, Sector 34-A, CHANDIGARH 160022 60 38 43

Southern : C.I.T. Campus, IV Cross Road, CHENNAI 600113 235 23 15

†Western : Manakalaya, E9, Behind Marol Telephone Exchange, Andheri (East),
MUMBAI 400093 832 92 95

Branch Offices::

'Pushpak', Nurmohamed Shaikh Marg, Khanpur, AHMEDABAD 380001 550 13 48

‡Peenya Industrial Area, 1st Stage, Bangalore-Tumkur Road,
BANGALORE 560058 839 49 55

Gangotri Complex, 5th Floor, Bhadbhada Road, T.T. Nagar, BHOPAL 462003 55 40 21

Plot No. 62-63, Unit VI, Ganga Nagar, BHUBANESHWAR 751001 40 36 27

Kalaikathir Buildings, 670 Avinashi Road, COIMBATORE 641037 21 01 41

Plot No. 43, Sector 16 A, Mathura Road, FARIDABAD 121001 8-28 88 01

Savitri Complex, 116 G.T. Road, GHAZIABAD 201001 8-71 19 96

53/5 Ward No.29, R.G. Barua Road, 5th By-lane, GUWAHATI 781003 54 11 37

5-8-56C, L.N. Gupta Marg, Nampally Station Road, HYDERABAD 500001 20 10 83

E-52, Chitaranjan Marg, C- Scheme, JAIPUR 302001 37 29 25

117/418 B, Sarvodaya Nagar, KANPUR 208005 21 68 76

Seth Bhawan, 2nd Floor, Behind Leela Cinema, Naval Kishore Road,
LUCKNOW 226001 23 89 23

NIT Building, Second Floor, Gokulpat Market, NAGPUR 440010 52 51 71

Patiputra Industrial Estate, PATNA 800013 26 23 05

Institution of Engineers (India) Building 1332 Shivaji Nagar, PUNE 411005 32 36 35

T.C. No. 14/1421, University P. O. Palayam, THIRUVANANTHAPURAM 695034 6 21 17

*Sales Office is at 5 Chowringhee Approach, P.O. Princep Street,
CALCUTTA 700072 27 10 85

†Sales Office is at Novelty Chambers, Grant Road, MUMBAI 400007 309 65 28

‡Sales Office is at 'F' Block, Unity Building, Narashimaraja Square,
BANGALORE 560002 222 39 71